

SULLAIR PAVING BREAKERS ARE DESIGNED TO WORK BETTER AND LAST LONG

FEWER WEARING PARTS, LESS MAINTENANCE, GREATER OPERATOR COMFORT, LESS FATIGUE, LESS AIR CONSUMPTION

THE SULLAIR PAVING BREAKERS ARE DESIGNED FOR WORK EFFICIENCY AND A LONG, TROUBLE-FREE LIFE.

High-Wear Parts Reduced

The Sullair breakers have eliminated most high-wear parts. Fewer parts mean less wear, less maintenance, and less downtime.

No Tappet System

Unlike conventional breakers, Sullair breakers have no multi-part tappet system. With fewer parts, wear is reduced and risk of air leaks is minimized. With no tappet system, which requires three independent impacts, noise is also reduced.

One Piece, Non-Protrusive Housing

A leakproof air cushion forms at the end of the piston stroke and stops the piston from direct impact when the tool is not breaking. The elimination of side rods, nuts and springs makes Sullair breakers sleeker and more comfortable to operate.

Minimal Lubrication Required

With only two parts moving during operation, normal oil carry-over from the compressor, combined with moisture in the air, will usually provide sufficient lubrication under normal operating conditions. Manual lubrication before storage is sufficient.

Direct Impact Piston

One moving impact part minimizes maintenance.

Parts Interchangeability

Standardization of design permits a high degree of interchangeability of parts between Sullair models.

Quieter

The piston, impacting directly on the steel shank rather than a tappet, reduces noise level of the breaker.

Super-Silenced/Anti-freeze Option

A unique silencer reduces noise levels by 6 dBA, while preventing the tool from freezing, even in the coldest climates.

Anti-Vibration Option

The flex handle option reduces up to 60% of the vibration to the operator without a loss of power.

Smoother Operation

Reduced kickback is less fatiguing to the operator.

Improved Latch Design

Durable double roll pin permits easy steel changing.

Less Air Consumption

The direct impact piston design, non-corrosive distribution valve and one-piece housing dramatically reduce air consumption. You can operate more tools from a single compressor. For example, a 125 cfm compressor will operate two MPB 90 breakers.

Two-Year Limited Warranty

All Sullair breaker parts are warranted for two years against manufacturing defects. Additionally, should a part wear out during normal operation, it is covered by Sullair's exclusive two-year warranty.

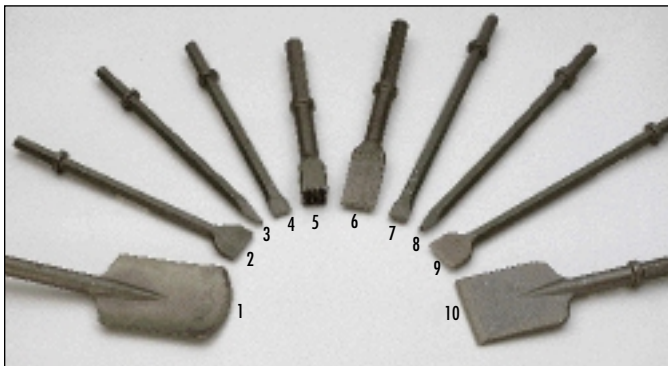

Paving Breaker Steels are available in 14" to 18" lengths, 7/8" X 3 3/4" to 1 1/4" X 6" shank size. Sullair's selection includes: (1) Clay Spades, (2 and 9) Wide Chisels, (3 and 8) Moil Points, (4 and 7) Narrow Chisels, (5) Bushing Tools, (6) Brick Wedges, and (10) Asphalt Cutters.

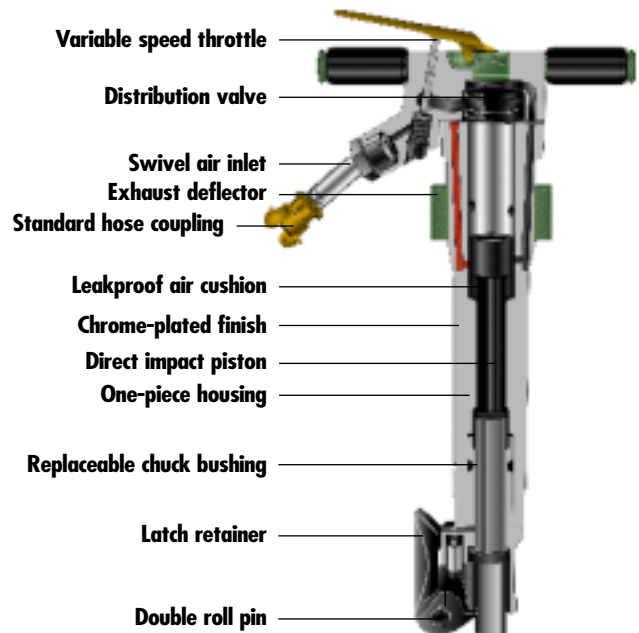

DESIGNED ER.

PAVING BREAKER DESIGN SPECIFICATIONS

Model	Weight lbs.	Length in.	Bore and Stroke in.	Blows/Minute	Air Consumption cfm	Air Inlet NPT	Shipping Weight lbs.	Chuck Size
MPB-90A	92	27½"	2⅞" x 5⅝"	1380	62 cfm	¾"	97	1⅛" HX x 6" 1¼" HX x 6"
MPB-60A	69½	26½"	2⅝" x 5⅝"	1360	48 cfm	¾"	74	1⅛" HX x 6" 1¼" HX x 6"
MPB-35C	39	25½"	1¾" x 5⅞"	1200	49 cfm	⅝"	43	1" HX x 4¼"
MPB-30A	35½	23"	1⅝" x 3⅝"	1850	37 cfm	⅝"	41	⅞" HX x 3¼" 1" HX x 4¼"
MPB-90AF	99½	28⅞"	2⅞" x 5⅝"	1380	62 cfm	¾"	105	1⅛" HX x 6" 1¼" HX x 6"
MPB-60AF	77	28⅞"	2⅝" x 5⅝"	1360	48 cfm	¾"	82	1⅛" HX x 6" 1¼" HX x 6"
MPB-90AS	94	27⅞"	2⅞" x 5⅝"	1380	62 cfm	¾"	101	1⅛" HX x 6" 1¼" HX x 6"
MPB-60AS	71½	26¾"	2⅝" x 5⅝"	1360	48 cfm	¾"	79	1⅛" HX x 6" 1¼" HX x 6"
MPB-90AFS	101	28⅞"	2⅞" x 5⅝"	1380	62 cfm	¾"	108	1⅛" HX x 6" 1¼" HX x 6"
MPB-60AFS	78½	28¼"	2⅝" x 5⅝"	1360	48 cfm	¾"	86	1⅛" HX x 6" 1¼" HX x 6"
MCD-30	33¾	24"	1⅝" x 3⅝"	1850	37 cfm	⅝"	39	⅞" HX x 3¼" 1" HX x 4¼"

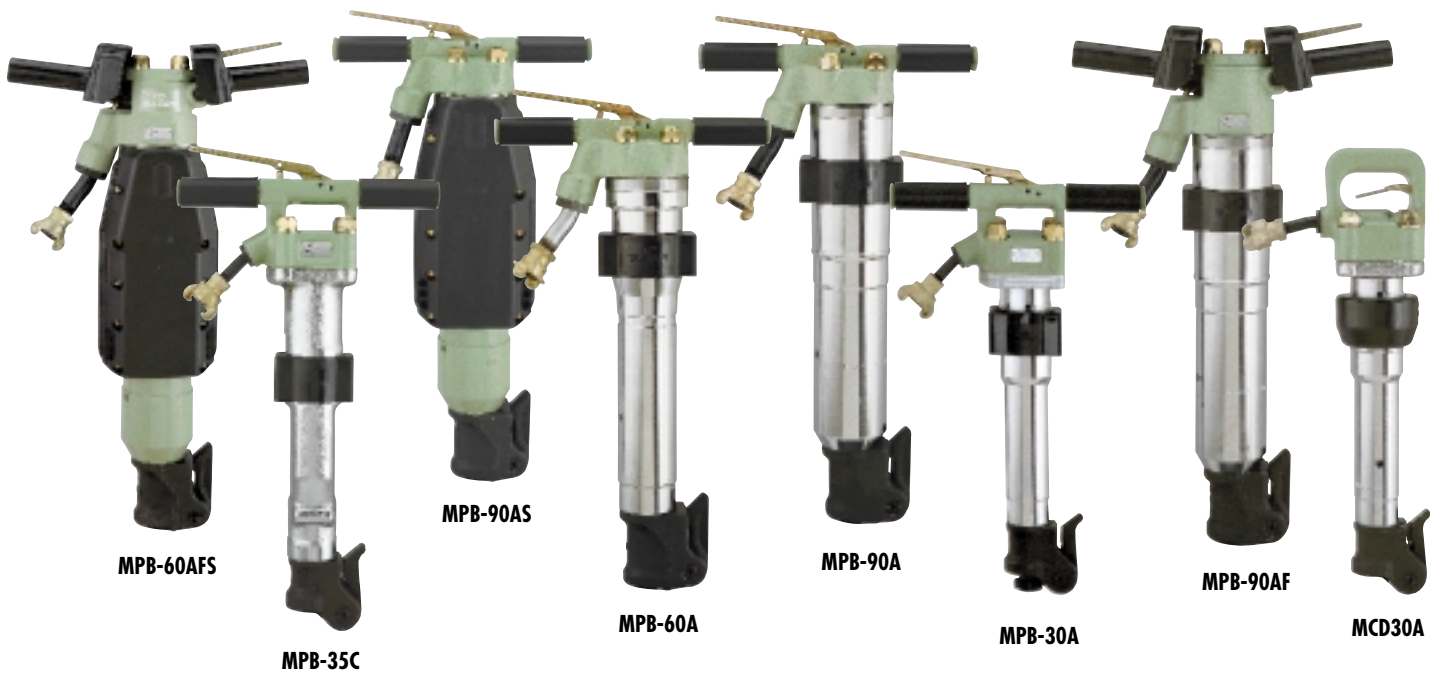

ANTI-VIBRATION PAVING BREAKER

ERGONOMICALLY DESIGNED, FEATURES A HINGED ANTI-VIBRATION HANDLE THAT REDUCES UP TO 60% OF VIBRATIONS TO THE OPERATOR WITHOUT LOSS OF POWER. BY ABSORBING THE SHOCK, THE ANTI-VIBRATION HANDLE REDUCES OPERATOR FATIGUE, LESSENS STRESS TO THE UPPER BACK AND SHOULDERS, AND ULTIMATELY PROMOTES PRODUCTIVITY.

Researching Breaker Vibration

This handle design is based on research conducted by Sullair's French operating unit, in association with the French government's INRS (equivalent to U.S.A.'s OSHA). Evaluating the stresses of paving breakers then in existence, the team found that the vibrations (often identified as kickback) came from pressure forces which act on both the body and the hitting piston of the machine. Research showed that breaker vibrations—at a rate of 1000 to 1500 per minute—are relayed through muscular contraction of the hands and arms to the rest of the body.

Finding the Ideal Solution

Over a period of years, the team investigated various approaches to reducing the effects of breaker vibration. Several prototypes were built and tested as the effort focused on developing a sturdier handle while providing simple and progressive start-up. The research culminated in the design of the Anti-Vibration Paving Breaker.

A Hinged Handle and Isolators

In this tool, vibrations are reduced by crossed handles that swivel on two pins on either side of the breaker head. The design provides sufficient clearance while keeping the handles compact. Two helical springs prevent direct contact between the handles and the body of the breaker. The tension of the springs not only provides sufficient thrust when the breaker is operating; it also allows the springs to act as efficient isolators.

Other Design Improvements

The new handle design led to other design improvements. For example, in order to hinge the handles correctly, the breaker's head—particularly the compressed air inlet—had to be completely redesigned.

Power Through Simplicity

The handle suspension system is independent and has no effect on the breaker's striking power. Based on a "power through simplicity" concept, the striking system uses a single piston that is guided through the entire length of the stroke.

No Tappet System

Unlike conventional breakers, Sullair breakers have no multi-part tappet system. With fewer parts, wear is reduced and risk of air leaks is minimized. With no tappet system, which requires three independent impacts, noise is also reduced.

High Impact Energy

Tests prove that these single piston breakers deliver more impact energy, pound for pound, than conventional breakers. The heavier long stroke also reduces piston speed, thus extending the life of the tool.

Less Air Needed

The breaker's direct impact piston design, non-corrosive distribution valve and one-piece housing dramatically reduce air consumption. As a result, more Anti-Vibration Paving Breakers can be operated from a single compressor.

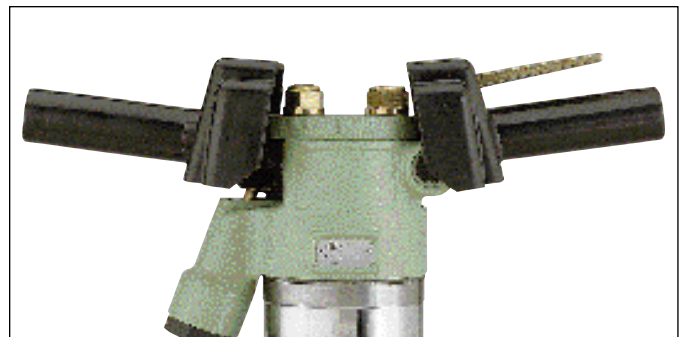

Anti-Vibration Handles